

| PARTS LIST |     |              |  |        |                    |               |
|------------|-----|--------------|--|--------|--------------------|---------------|
| ITEM       | QTY | PART NO.     | PART DESCRIPTION   | LENGTH | UNIT WT.           | NET WT.       |
| 1          | 1   | FACE-ASY1-NP | SINGLE SECTOR FACE MOUNT KIT (NO PIPE)                         |        | 565.23             | 565.23        |
| 2          | 1   | FACE-PM496   | FACE ASSEMBLY PIPE MOUNT KIT                                   |        | 145.77             | 145.77        |
| 3          | 2   | P3180        | 3" SCH. 40 PIPE (3.5" O.D. X 0.226" - A53 GR. B Fy=35 ksi min) | 180 in | 120.58             | 241.17        |
|            |     |              |  |        | <b>TOTAL WT. #</b> | <b>938.52</b> |

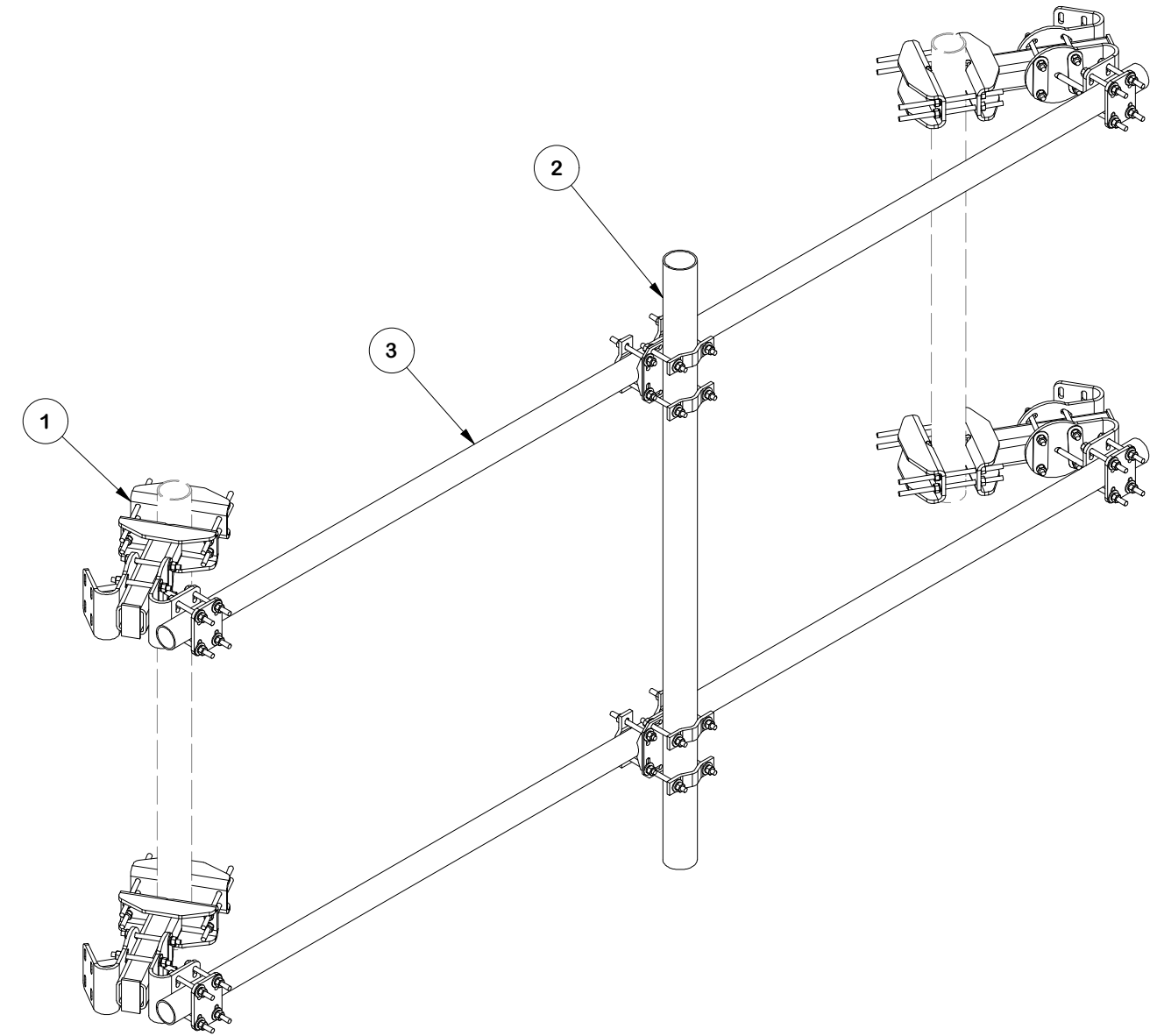
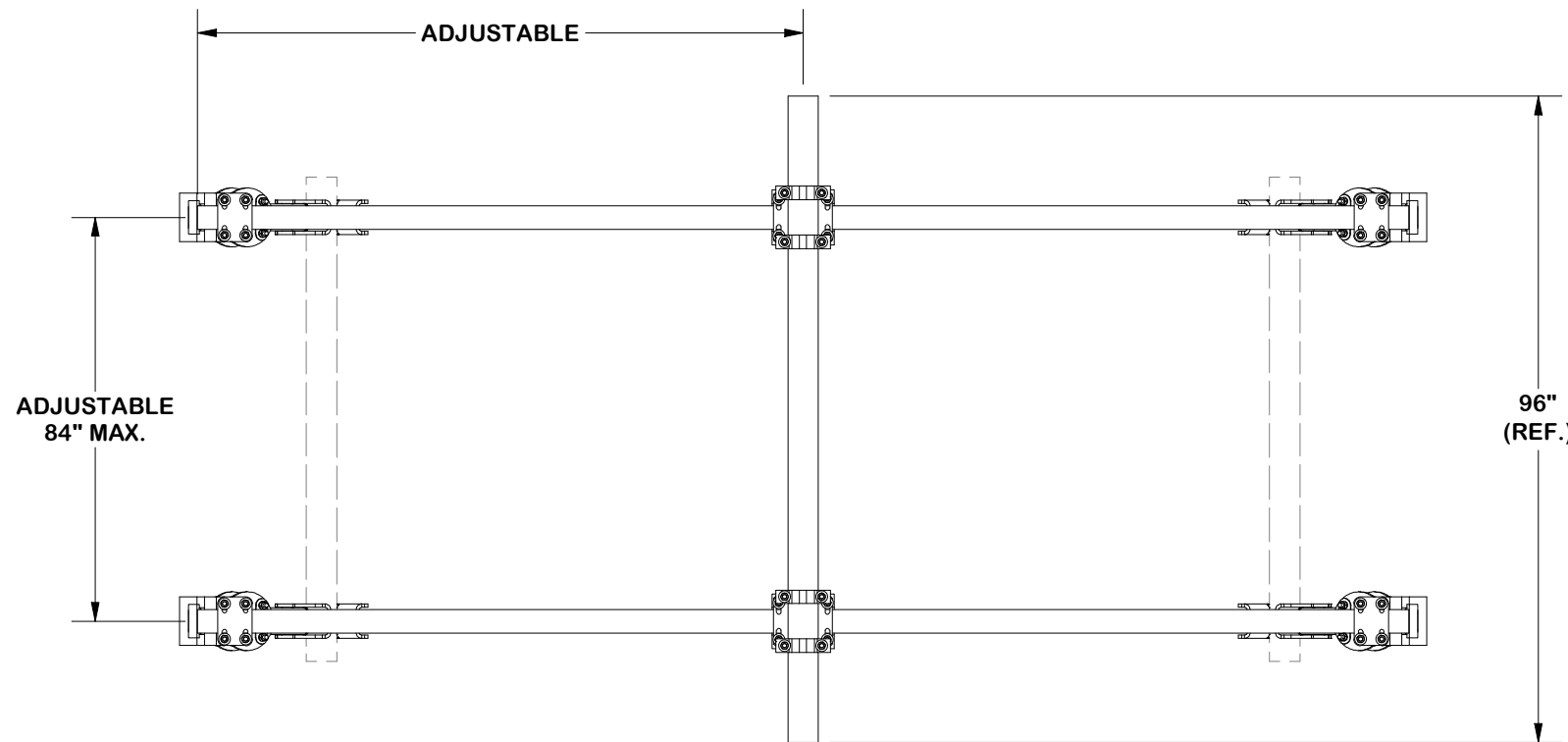
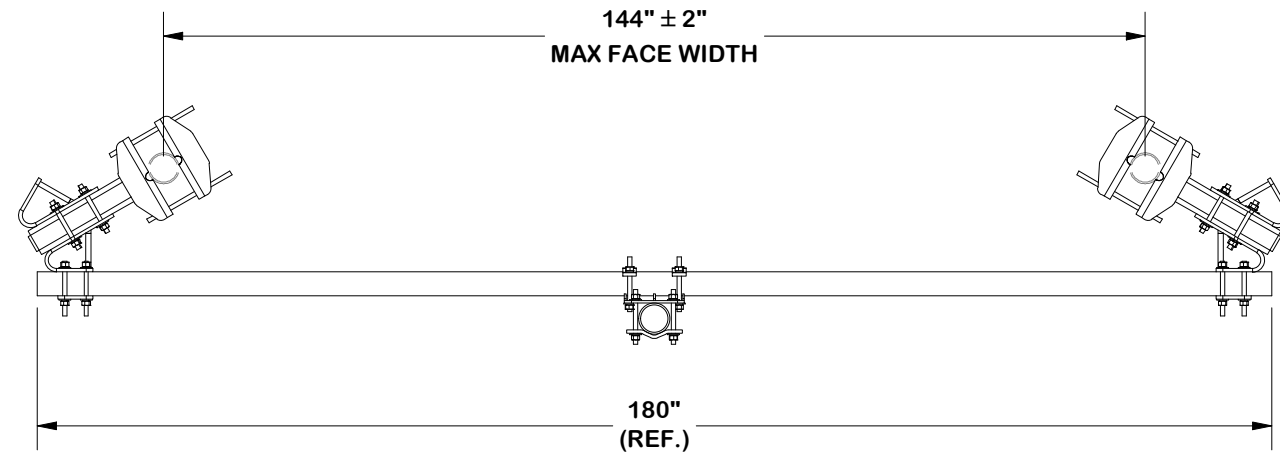

FINISH:  
HOT DIP GALVANIZED.

**TOLERANCE NOTES**

TOLERANCES ON DIMENSIONS, UNLESS OTHERWISE NOTED ARE:  
 SAWED, SHEARED AND GAS CUT EDGES ( $\pm 0.030"$ )  
 DRILLED AND GAS CUT HOLES ( $\pm 0.030"$ ) - NO CONING OF HOLES  
 LASER CUT EDGES AND HOLES ( $\pm 0.010"$ ) - NO CONING OF HOLES  
 BENDS AND ANGLES ARE  $\pm 1/2$  DEGREE  
 ALL OTHER MACHINING ( $\pm 0.030"$ )  
 ALL OTHER ASSEMBLY ( $\pm 0.060"$ )

PATENT INFORMATION: WWW.SITEPRO1.COM/PATENTS

PROPRIETARY NOTE:  
 THE DATA AND TECHNIQUES CONTAINED IN THIS DRAWING ARE PROPRIETARY INFORMATION OF VALMONT INDUSTRIES AND CONSIDERED A TRADE SECRET. ANY USE OR DISCLOSURE WITHOUT THE CONSENT OF VALMONT INDUSTRIES IS STRICTLY PROHIBITED.

DESCRIPTION  
**SINGLE-SECTOR MICROWAVE KIT  
 W/ 3-1/2" DIA. X 180" HORIZONTALS  
 AND PIPE MOUNT**

|                                    |                                 |                                   |
|------------------------------------|---------------------------------|-----------------------------------|
| CPD NO.<br><b>SP1</b>              | DRAWN BY<br><b>SDR 3/4/2026</b> | ENG. APPROVAL<br><b>3/11/2026</b> |
| CLASS<br><b>87</b>                 | SUB<br><b>02</b>                | DRAWING USAGE<br><b>CUSTOMER</b>  |
| CHECKED BY<br><b>CSL 3/11/2026</b> |                                 |                                   |



Engineering  
 Support Team:  
 sp1engineering@valmont.com

A valmont COMPANY

|                            |
|----------------------------|
| PART NO.<br><b>FMW14-3</b> |
| DWG. NO.<br><b>FMW14-3</b> |

**NOTES:**

1. THE MAXIMUM TAPER ADJUSTMENT IS 8° BASED UPON 60" SPACING OF ADJUSTABLE MOUNTING BRACKETS.

| PARTS LIST         |     |             |               |  |               |         |
|--------------------|-----|-------------|---------------|--|---------------|---------|
| ITEM               | QTY | PART NO.    | BOX NO.       | PART DESCRIPTION                       | UNIT WT.      | NET WT. |
| 1                  | 8   | FACE-CCHALF | P-FACE-CCHALF | FACE ASSEMBLY CORNER CONNECTION (HALF) | 33.15         | 265.20  |
| 2                  | 4   | FACE-LC     | P-FACE-LC     | FACE ASSEMBLY LEG CONNECTION           | 26.99         | 107.96  |
| 3                  | 4   | X-FACE-TW   |               | TUBE WELDMENT                          | 48.02         | 192.07  |
| <b>TOTAL WT. #</b> |     |             |               |  | <b>565.23</b> |         |

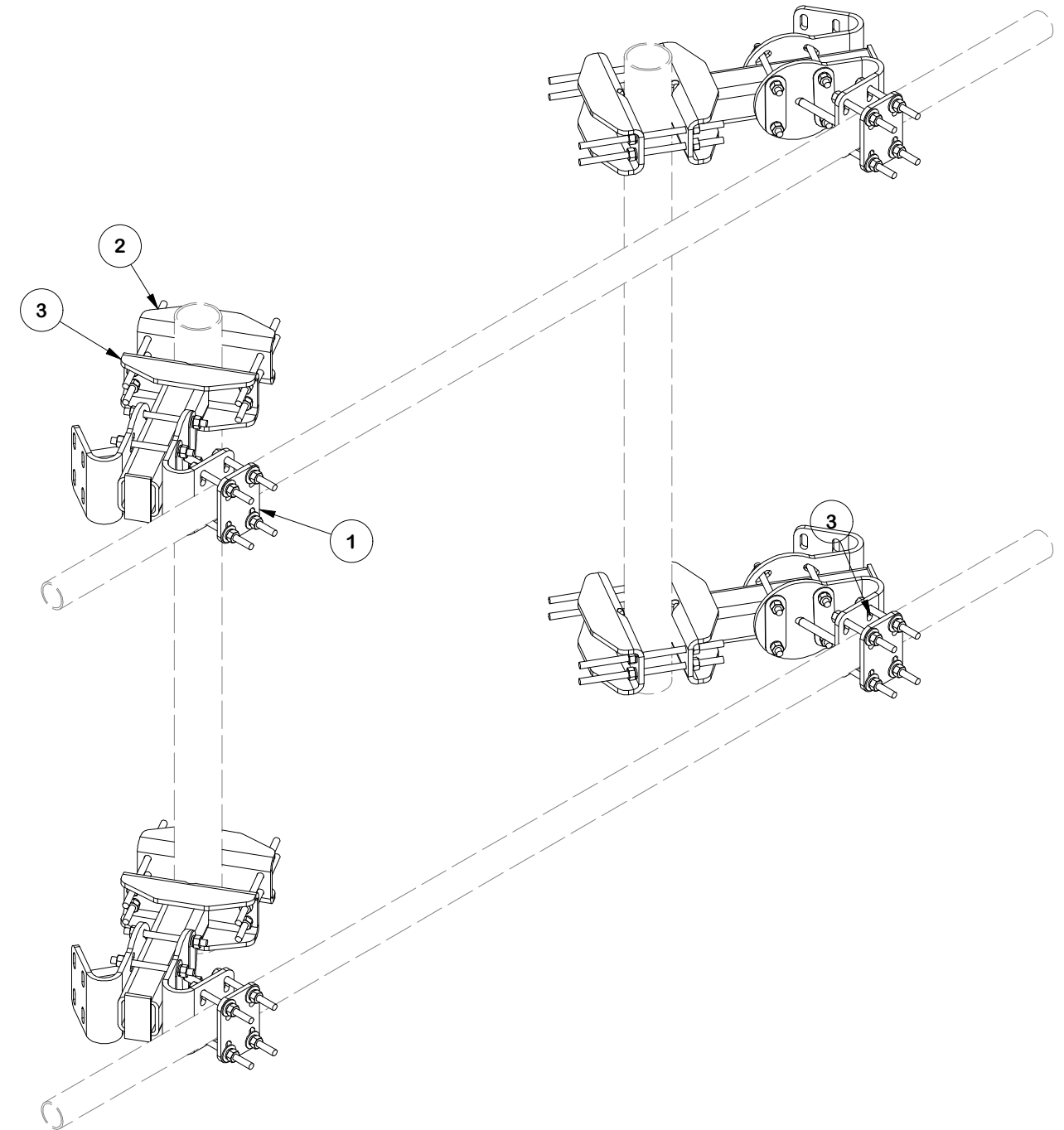
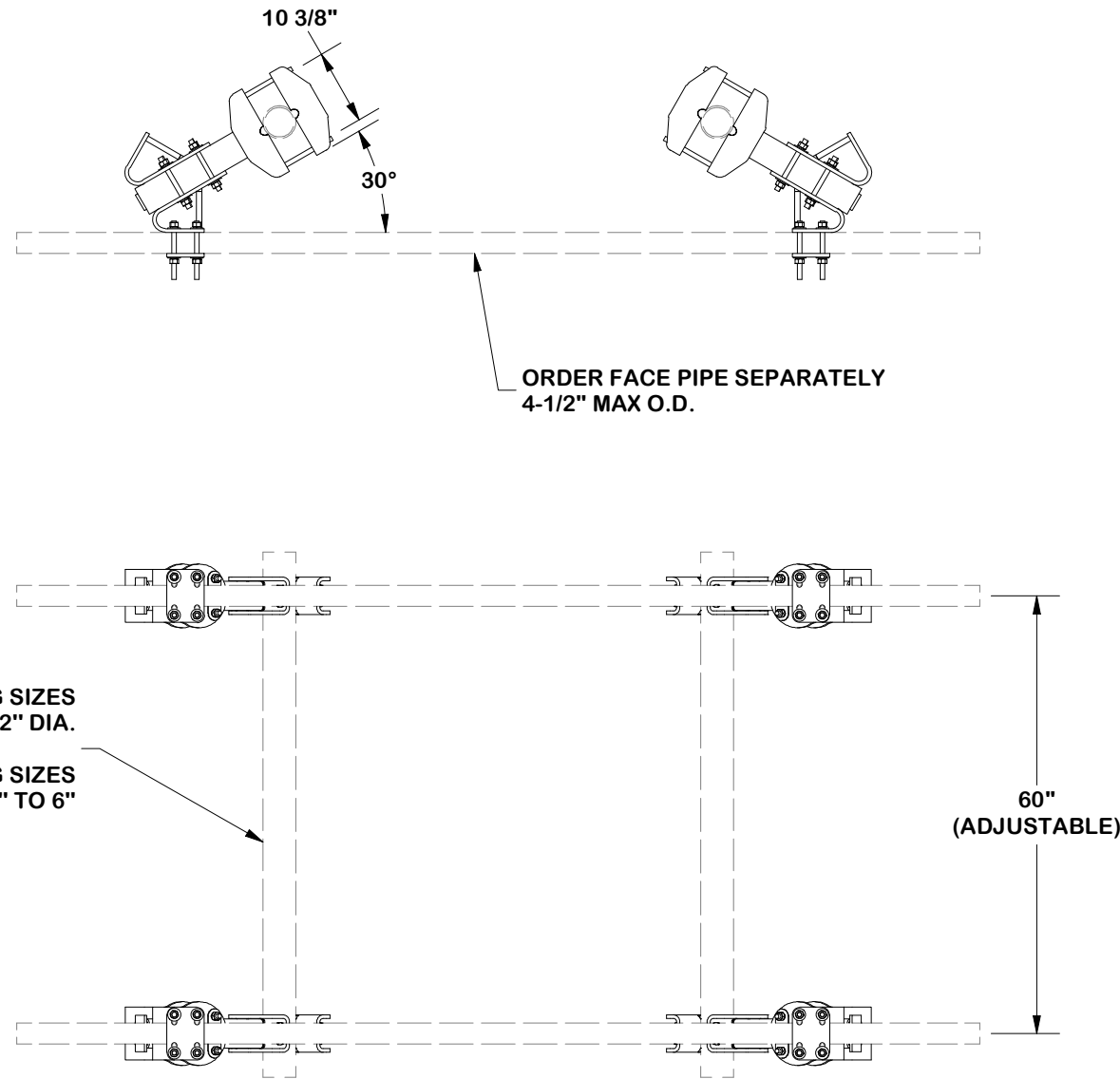

**FINISH:**  
HOT DIP GALVANIZED.

**TOLERANCE NOTES**

TOLERANCES ON DIMENSIONS, UNLESS OTHERWISE NOTED ARE:  
 SAWED, SHEARED AND GAS CUT EDGES ( $\pm 0.030"$ )  
 DRILLED AND GAS CUT HOLES ( $\pm 0.030"$ ) - NO CONING OF HOLES  
 LASER CUT EDGES AND HOLES ( $\pm 0.010"$ ) - NO CONING OF HOLES  
 BENDS AND ANGLES ARE  $\pm 1/2$  DEGREE  
 ALL OTHER MACHINING ( $\pm 0.030"$ )  
 ALL OTHER ASSEMBLY ( $\pm 0.060"$ )

PROPRIETARY NOTE:  
 THE DATA AND TECHNIQUES CONTAINED IN THIS DRAWING ARE PROPRIETARY INFORMATION OF VALMONT INDUSTRIES AND CONSIDERED A TRADE SECRET. ANY USE OR DISCLOSURE WITHOUT THE CONSENT OF VALMONT INDUSTRIES IS STRICTLY PROHIBITED.

DESCRIPTION  
**SINGLE-SECTOR MICROWAVE KIT  
 W/ 3-1/2" DIA. X 180" HORIZONTALS  
 AND PIPE MOUNT**



Engineering Support Team:  
 sp1engineering@valmont.com

| REV                     | DESCRIPTION OF REVISIONS           | CPD | BY  | DATE       |
|-------------------------|------------------------------------|-----|-----|------------|
| B                       | REVISED DRAWING TO SINGLE ASSEMBLY | SP1 | ADB | 11/18/2025 |
| A                       | ADDED VIEWS FOR CLARITY            | SP1 | ADB | 9/16/2025  |
| <b>REVISION HISTORY</b> |                                    |     |     |            |

PATENT INFORMATION: WWW.SITEPRO1.COM/PATENTS

|                       |                        |                                  |                                   |
|-----------------------|------------------------|----------------------------------|-----------------------------------|
| CPD NO.<br><b>SP1</b> | DRAWN BY<br><b>SDR</b> | 3/4/2026                         | ENG. APPROVAL<br><b>3/11/2026</b> |
| CLASS<br><b>87</b>    | SUB<br><b>02</b>       | DRAWING USAGE<br><b>CUSTOMER</b> | CHECKED BY<br><b>CSL</b>          |
|                       |                        | 3/11/2026                        |                                   |

|                                 |                       |
|---------------------------------|-----------------------|
| PART NO.<br><b>FACE-ASY1-NP</b> | <b>2 OF 6</b><br>PAGE |
| DWG. NO.<br><b>FMW14-3</b>      |                       |

| PARTS LIST |     |           |                               |          |             |         |
|------------|-----|-----------|-------------------------------|----------|-------------|---------|
| ITEM       | QTY | PART NO.  | PART DESCRIPTION              | LENGTH   | UNIT WT.    | NET WT. |
| 1          | 1   | X-FACE-TA | TAPER ADJUSTMENT WELDMENT     |          | 20.84       | 20.84   |
| 2          | 1   | X-FACE-CP | CONNECTION PLATE              | 12 in    | 4.80        | 4.80    |
| 3          | 2   | X-FACE-SB | SPACER BRACKET (WASHER)       | 6 3/4 in | 0.45        | 0.90    |
| 4          | 6   | G58R-8    | 5/8" x 8" THREADED ROD (HDG.) |          | 0.70        | 4.18    |
| 5          | 8   | G58FW     | 5/8" HDG USS FLATWASHER       | 1/8 in   | 0.07        | 0.56    |
| 6          | 12  | G58LW     | 5/8" HDG LOCKWASHER           |          | 0.03        | 0.31    |
| 7          | 12  | G58NUT    | 5/8" HDG HEAVY 2H HEX NUT     |          | 0.13        | 1.56    |
|            |     |           |                               |          | TOTAL WT. # | 33.15   |

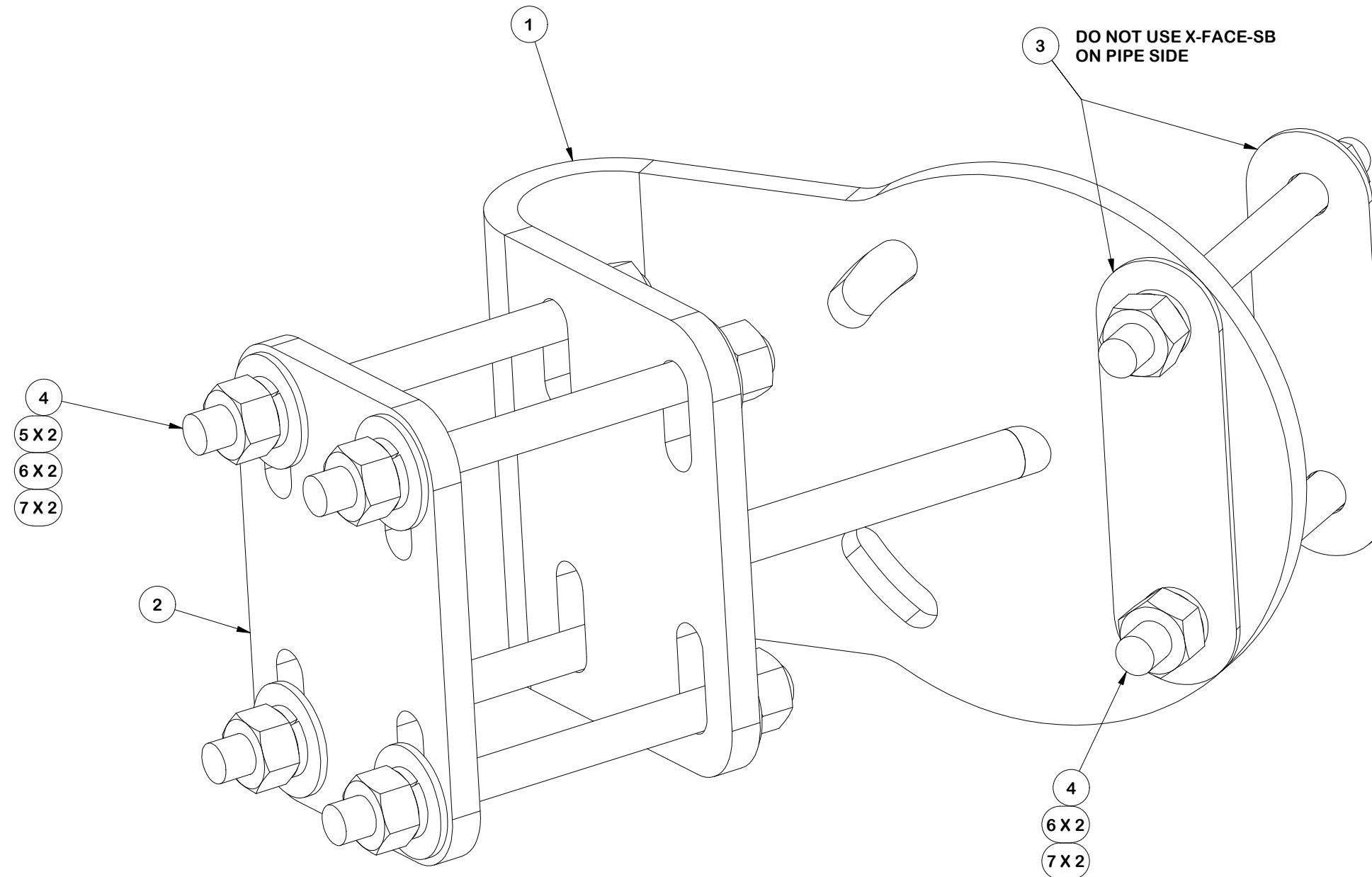

FINISH:  
HOT DIP GALVANIZED.

**TOLERANCE NOTES**

TOLERANCES ON DIMENSIONS, UNLESS OTHERWISE NOTED ARE:  
 SAWED, SHEARED AND GAS CUT EDGES ( $\pm 0.030"$ )  
 DRILLED AND GAS CUT HOLES ( $\pm 0.030"$ ) - NO CONING OF HOLES  
 LASER CUT EDGES AND HOLES ( $\pm 0.010"$ ) - NO CONING OF HOLES  
 BENDS AND ANGLES ARE  $\pm 1/2$  DEGREE  
 ALL OTHER MACHINING ( $\pm 0.030"$ )  
 ALL OTHER ASSEMBLY ( $\pm 0.060"$ )

PATENT INFORMATION: WWW.SITEPRO1.COM/PATENTS

PROPRIETARY NOTE:  
 THE DATA AND TECHNIQUES CONTAINED IN THIS DRAWING ARE PROPRIETARY INFORMATION OF VALMONT INDUSTRIES AND CONSIDERED A TRADE SECRET. ANY USE OR DISCLOSURE WITHOUT THE CONSENT OF VALMONT INDUSTRIES IS STRICTLY PROHIBITED.

DESCRIPTION  
**SINGLE-SECTOR MICROWAVE KIT  
 W/ 3-1/2" DIA. X 180" HORIZONTALS  
 AND PIPE MOUNT**

|                                    |                                 |                                   |
|------------------------------------|---------------------------------|-----------------------------------|
| CPD NO.<br><b>SP1</b>              | DRAWN BY<br><b>SDR 3/4/2026</b> | ENG. APPROVAL<br><b>3/11/2026</b> |
| CLASS<br><b>87</b>                 | SUB<br><b>02</b>                | DRAWING USAGE<br><b>CUSTOMER</b>  |
| CHECKED BY<br><b>CSL 3/11/2026</b> |                                 |                                   |



A valmont COMPANY

Engineering Support Team:  
 sp1engineering@valmont.com

|                                |
|--------------------------------|
| PART NO.<br><b>FACE-CCHALF</b> |
| DWG. NO.<br><b>FMW14-3</b>     |

| PARTS LIST |     |           |                                |        |             |         |
|------------|-----|-----------|--------------------------------|--------|-------------|---------|
| ITEM       | QTY | PART NO.  | PART DESCRIPTION               | LENGTH | UNIT WT.    | NET WT. |
| 1          | 1   | X-FACE-BP | BENT PLATE FOR X-HDCAMTBW      | 13 in  | 18.08       | 18.08   |
| 2          | 4   | G58R-14   | 5/8" x 14" THREADED ROD (HDG.) |        | 1.22        | 4.88    |
| 3          | 4   | G58R-8    | 5/8" x 8" THREADED ROD (HDG.)  |        | 0.70        | 2.79    |
| 4          | 8   | G58LW     | 5/8" HDG LOCKWASHER            |        | 0.03        | 0.21    |
| 5          | 8   | G58NUT    | 5/8" HDG HEAVY 2H HEX NUT      |        | 0.13        | 1.04    |
|            |     |           |                                |        | TOTAL WT. # | 26.99   |

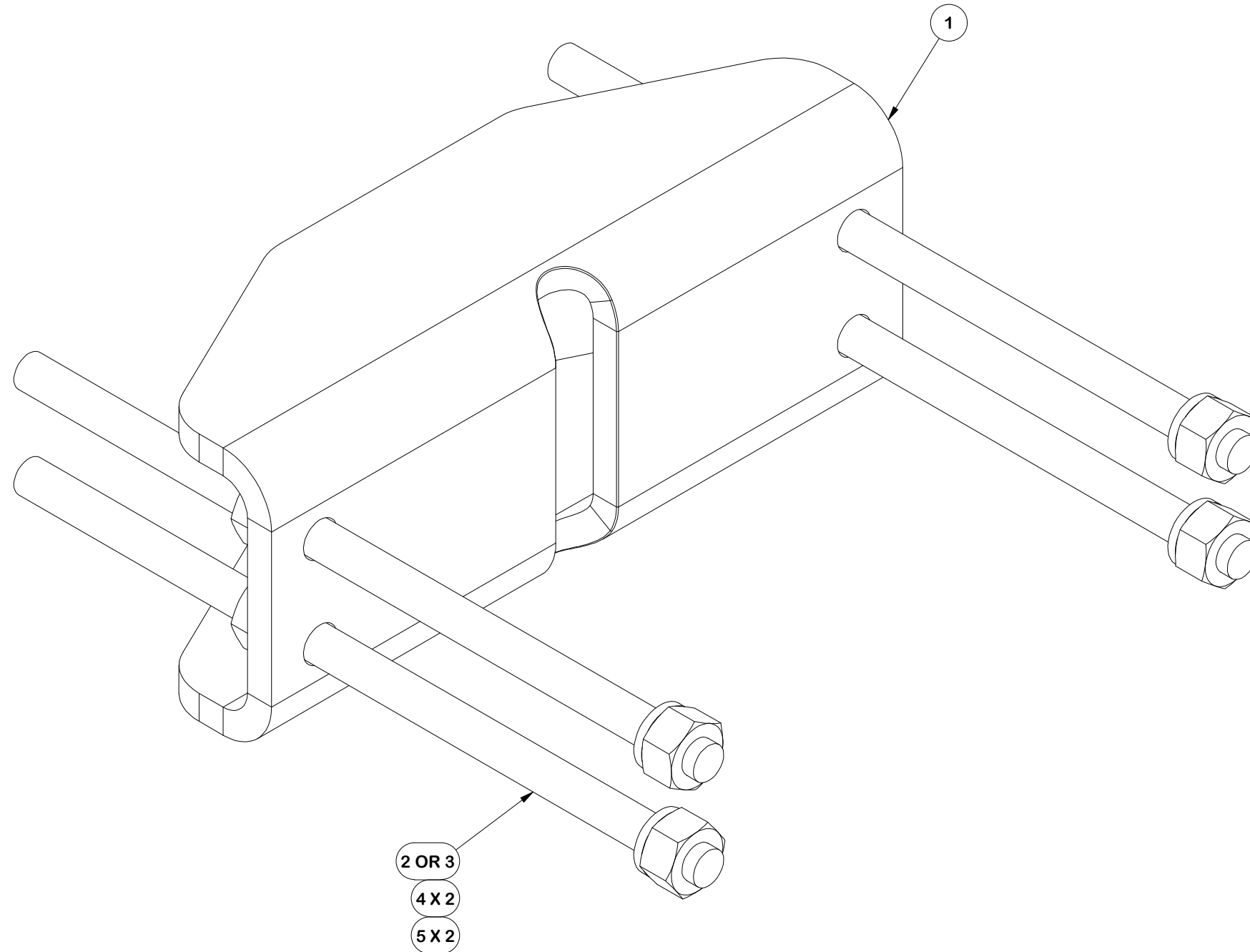

**FINISH:**  
HOT DIP GALVANIZED.

**TOLERANCE NOTES**

TOLERANCES ON DIMENSIONS, UNLESS OTHERWISE NOTED ARE:  
 SAWED, SHEARED AND GAS CUT EDGES ( $\pm 0.030"$ )  
 DRILLED AND GAS CUT HOLES ( $\pm 0.030"$ ) - NO CONING OF HOLES  
 LASER CUT EDGES AND HOLES ( $\pm 0.010"$ ) - NO CONING OF HOLES  
 BENDS AND ANGLES ARE  $\pm 1/2$  DEGREE  
 ALL OTHER MACHINING ( $\pm 0.030"$ )  
 ALL OTHER ASSEMBLY ( $\pm 0.060"$ )

PATENT INFORMATION: WWW.SITEPRO1.COM/PATENTS

PROPRIETARY NOTE:  
 THE DATA AND TECHNIQUES CONTAINED IN THIS DRAWING ARE PROPRIETARY INFORMATION OF VALMONT INDUSTRIES AND CONSIDERED A TRADE SECRET. ANY USE OR DISCLOSURE WITHOUT THE CONSENT OF VALMONT INDUSTRIES IS STRICTLY PROHIBITED.

DESCRIPTION  
**SINGLE-SECTOR MICROWAVE KIT  
 W/ 3-1/2" DIA. X 180" HORIZONTALS  
 AND PIPE MOUNT**

|                                    |                                 |                                   |
|------------------------------------|---------------------------------|-----------------------------------|
| CPD NO.<br><b>SP1</b>              | DRAWN BY<br><b>SDR</b> 3/4/2026 | ENG. APPROVAL<br><b>3/11/2026</b> |
| CLASS<br><b>87</b>                 | SUB<br><b>02</b>                | DRAWING USAGE<br><b>CUSTOMER</b>  |
| CHECKED BY<br><b>CSL</b> 3/11/2026 |                                 |                                   |



Engineering Support Team:  
 sp1engineering@valmont.com

A valmont COMPANY

|                            |
|----------------------------|
| PART NO.<br><b>FACE-LC</b> |
| DWG. NO.<br><b>FMW14-3</b> |

| PARTS LIST |     |          |           |                                      |  |       | LENGTH      | UNIT WT. | NET WT. |
|------------|-----|----------|-----------|--------------------------------------|--|-------|-------------|----------|---------|
| ITEM       | QTY | PART NO. | BOX NO.   | PART DESCRIPTION                     |  |       |             |          |         |
| 1          | 1   | P496     |           | 4-1/2" X 96" SCH. 40 GALVANIZED PIPE |  | 96 in | 91.60       | 91.60    |         |
| 2          | 2   | FCX45-U  | P-FCX45-U | HEAVY-DUTY UNIVERSAL CROSSOVER KIT   |  |       | 27.08       | 54.17    |         |
|            |     |          |           |                                      |  |       | TOTAL WT. # | 145.77   |         |

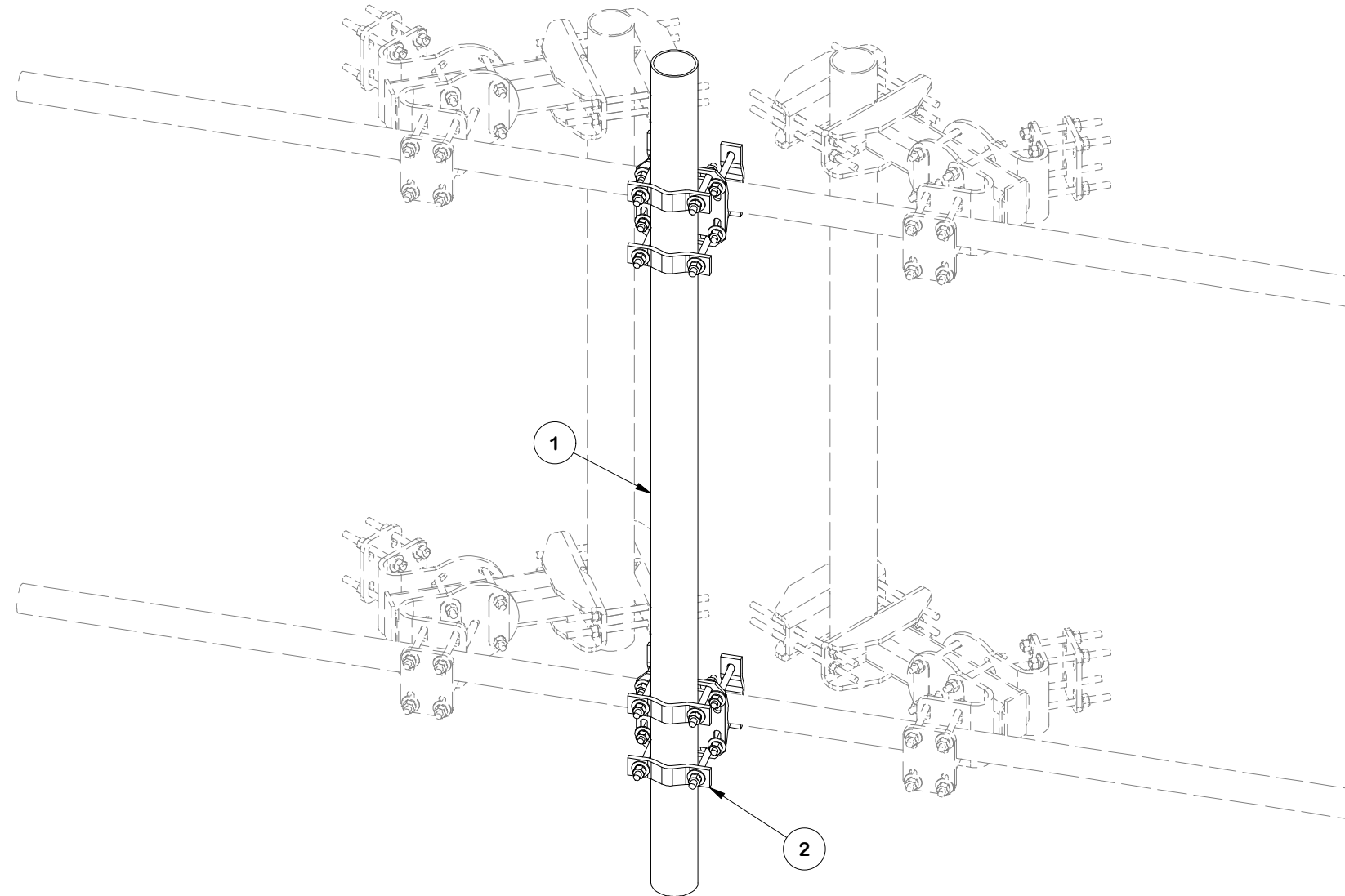

**FINISH:**  
HOT DIP GALVANIZED.

**TOLERANCE NOTES**

TOLERANCES ON DIMENSIONS, UNLESS OTHERWISE NOTED ARE:  
 SAWED, SHEARED AND GAS CUT EDGES ( $\pm 0.030"$ )  
 DRILLED AND GAS CUT HOLES ( $\pm 0.030"$ ) - NO CONING OF HOLES  
 LASER CUT EDGES AND HOLES ( $\pm 0.010"$ ) - NO CONING OF HOLES  
 BENDS AND ANGLES ARE  $\pm 1/2$  DEGREE  
 ALL OTHER MACHINING ( $\pm 0.030"$ )  
 ALL OTHER ASSEMBLY ( $\pm 0.060"$ )

PATENT INFORMATION: WWW.SITEPRO1.COM/PATENTS

PROPRIETARY NOTE:  
 THE DATA AND TECHNIQUES CONTAINED IN THIS DRAWING ARE PROPRIETARY INFORMATION OF VALMONT INDUSTRIES AND CONSIDERED A TRADE SECRET. ANY USE OR DISCLOSURE WITHOUT THE CONSENT OF VALMONT INDUSTRIES IS STRICTLY PROHIBITED.

DESCRIPTION  
**SINGLE-SECTOR MICROWAVE KIT  
 W/ 3-1/2" DIA. X 180" HORIZONTALS  
 AND PIPE MOUNT**

|         |               |               |
|---------|---------------|---------------|
| CPD NO. | DRAWN BY      | ENG. APPROVAL |
| SP1     | SDR 3/4/2026  | 3/11/2026     |
| CLASS   | DRAWING USAGE | CHECKED BY    |
| 87      | CUSTOMER      | CSL 3/11/2026 |



Engineering Support Team:  
 sp1engineering@valmont.com

|          |            |
|----------|------------|
| PART NO. | FACE-PM496 |
| DWG. NO. | FMW14-3    |

| PARTS LIST |     |           |  |          |             |         |
|------------|-----|-----------|--|----------|-------------|---------|
| ITEM       | QTY | PART NO.  | PART DESCRIPTION                             | LENGTH   | UNIT WT.    | NET WT. |
| 1          | 1   | X-SCX4-FR | 4-1/2" FORTRESS CROSSOVER PLATE              |          | 8.10        | 8.10    |
| 2          | 4   | DCP       | 1/2" THICK, 5-3/4" CNTR TO CENTER CLAMP HALF | 8 1/8 in | 2.36        | 9.45    |
| 3          | 8   | G5807     | 5/8" x 7" HDG HEX BOLT GR5 FULL THREAD       | 7 in     | 0.70        | 5.64    |
| 4          | 16  | G58FW     | 5/8" HDG USS FLATWASHER                      | 1/8 in   | 0.07        | 1.13    |
| 5          | 8   | G58LW     | 5/8" HDG LOCKWASHER                          |          | 0.03        | 0.21    |
| 6          | 8   | G58NUT    | 5/8" HDG HEAVY 2H HEX NUT                    |          | 0.13        | 1.04    |
|            |     |           |  |          | TOTAL WT. # | 25.62   |

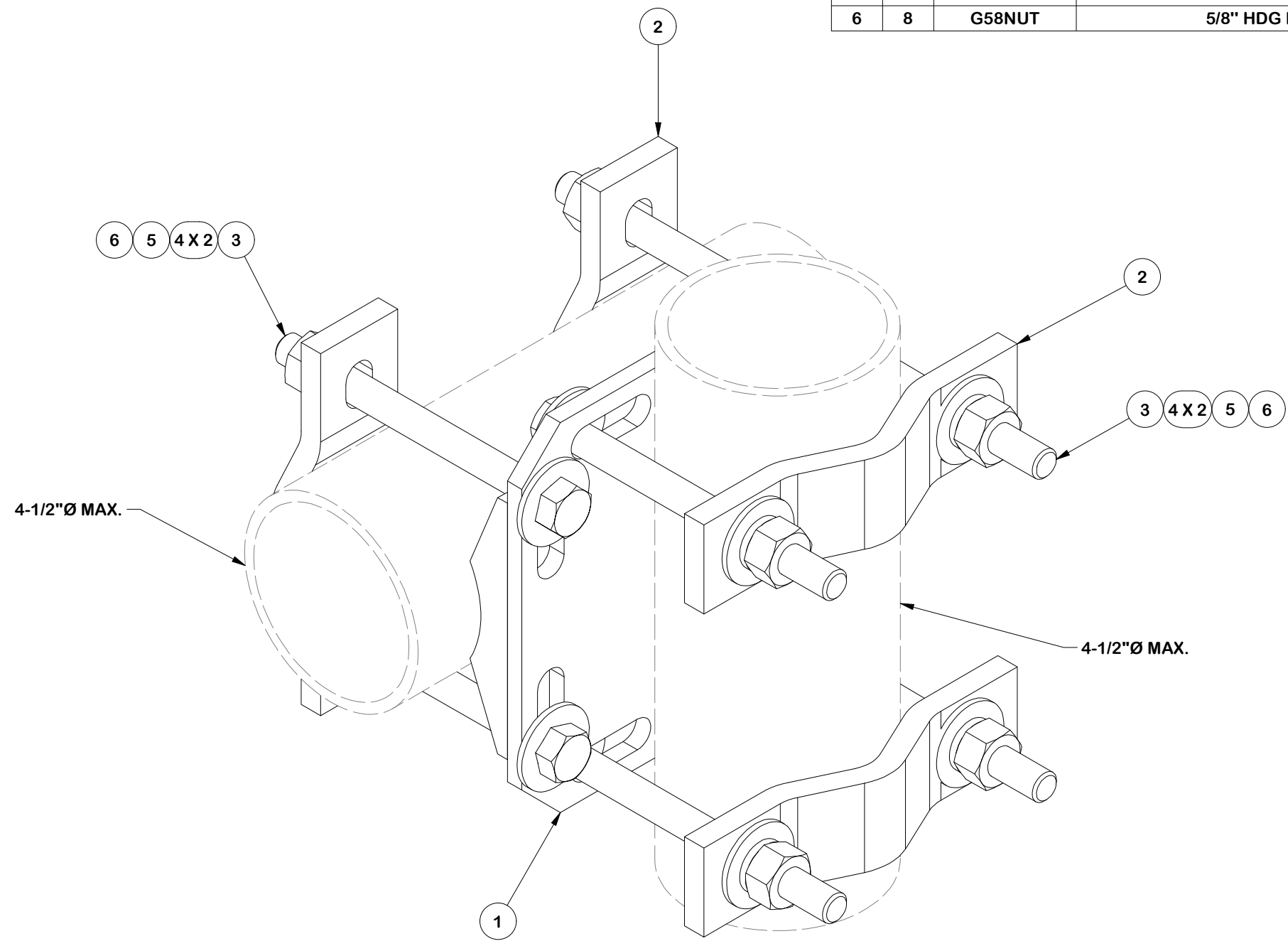

FINISH:  
HOT DIP GALVANIZED.

**TOLERANCE NOTES**

TOLERANCES ON DIMENSIONS, UNLESS OTHERWISE NOTED ARE:  
 SAWED, SHEARED AND GAS CUT EDGES ( $\pm 0.030"$ )  
 DRILLED AND GAS CUT HOLES ( $\pm 0.030"$ ) - NO CONING OF HOLES  
 LASER CUT EDGES AND HOLES ( $\pm 0.010"$ ) - NO CONING OF HOLES  
 BENDS AND ANGLES ARE  $\pm 1/2$  DEGREE  
 ALL OTHER MACHINING ( $\pm 0.030"$ )  
 ALL OTHER ASSEMBLY ( $\pm 0.060"$ )

PATENT INFORMATION: WWW.SITEPRO1.COM/PATENTS

PROPRIETARY NOTE:  
 THE DATA AND TECHNIQUES CONTAINED IN THIS DRAWING ARE PROPRIETARY INFORMATION OF VALMONT INDUSTRIES AND CONSIDERED A TRADE SECRET. ANY USE OR DISCLOSURE WITHOUT THE CONSENT OF VALMONT INDUSTRIES IS STRICTLY PROHIBITED.

DESCRIPTION  
**SINGLE-SECTOR MICROWAVE KIT  
 W/ 3-1/2" DIA. X 180" HORIZONTALS  
 AND PIPE MOUNT**

|                                    |                                 |                                   |
|------------------------------------|---------------------------------|-----------------------------------|
| CPD NO.<br><b>SP1</b>              | DRAWN BY<br><b>SDR 3/4/2026</b> | ENG. APPROVAL<br><b>3/11/2026</b> |
| CLASS<br><b>87</b>                 | SUB<br><b>02</b>                | DRAWING USAGE<br><b>CUSTOMER</b>  |
| CHECKED BY<br><b>CSL 3/11/2026</b> |                                 |                                   |

**SITE PRO 1**  
 A valmont COMPANY

Engineering Support Team:  
 sp1engineering@valmont.com

|                            |                |
|----------------------------|----------------|
| PART NO.<br><b>FCX45-U</b> | PAGE<br>6 OF 6 |
| DWG. NO.<br><b>FMW14-3</b> |                |